

NEG ARG FIBRE

Chopped Strands

ACS13H-950X(20)/V



ACS13H-950X(20)/V is made of glass, which contains the largest content of ZrO_2 commercially available.

ACS13H-950X is a high integrity strand to meet the requirements of conventional "premix" products. Chopped fibres disperse as strands in a matrix of mortar. Excellent strand integrity also allows keeping good moldability of mortar containing glass fibres.

ACS13H-950X has quality approval by DIBt (Deutsches Institut für Bautechnik) No. Z-3.72-1730.

■ Product Specifications

Type of Glass ——— Alkali Resistant glass
Nominal tex (g/1000m) ——— 78
Cut length (mm)* ——— 13
Moisture content (%)* ——— less than 0.5

*Data measured by JIS (Japanese Industrial Standard)

■ Process

Premix, Casting

■ Applications

Glass fibre reinforced concrete (GRC)

■ GRC Products Using NEG ARG Fibre ACS13H-950X Include:

For Architecture

Sun Screen, balcony element, parapet panel, flooring, roofing tile, etc.

For Civil Engineering

Cable trough, water trough, etc.

For Other Application

Garden furniture, artificial rock, fence, etc.

■ Packaging Data

20 kg in a polyethylene bag

■ Palletizing Data

Number of packages/pallet	36
Pallet Dimensions (mm)	
Length	1440
Width	1150
Height	1070

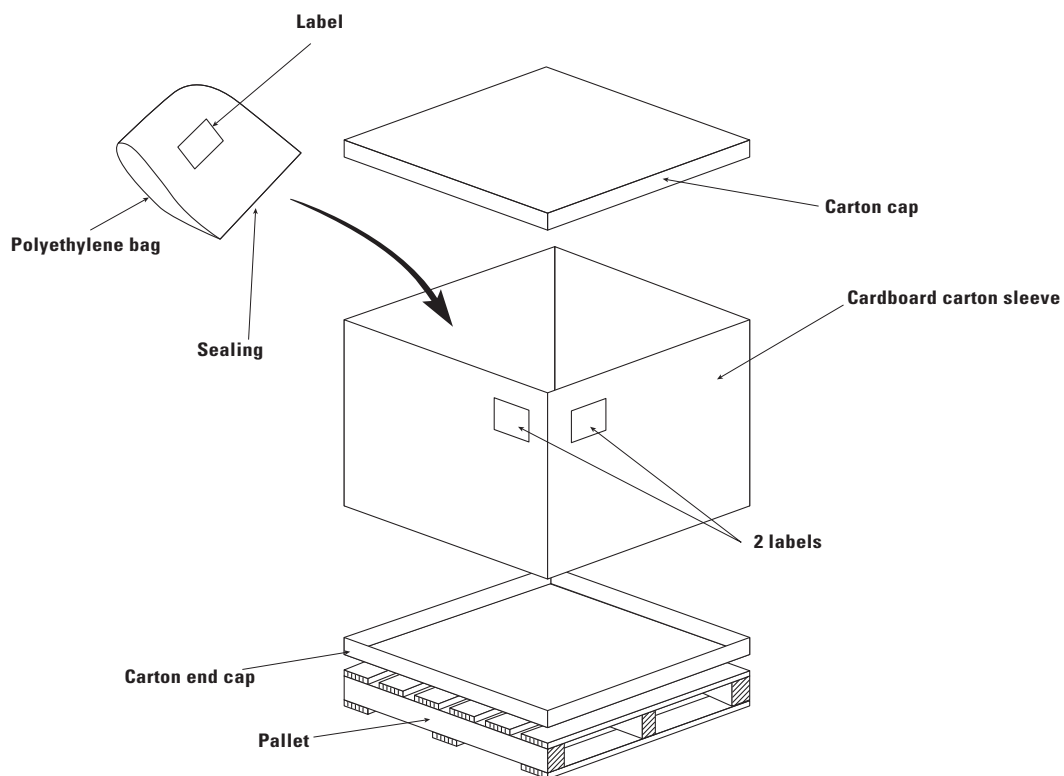

■ Storage Conditions

ACS13H-950X should be stored in an upright position in a dry area in its original packaging.
ACS13H-950X should be sheltered from the direct sunlight.

* NEG reserves the right to change the features and specifications of its products without prior notice

