

PS10,000i GRC Spray Station

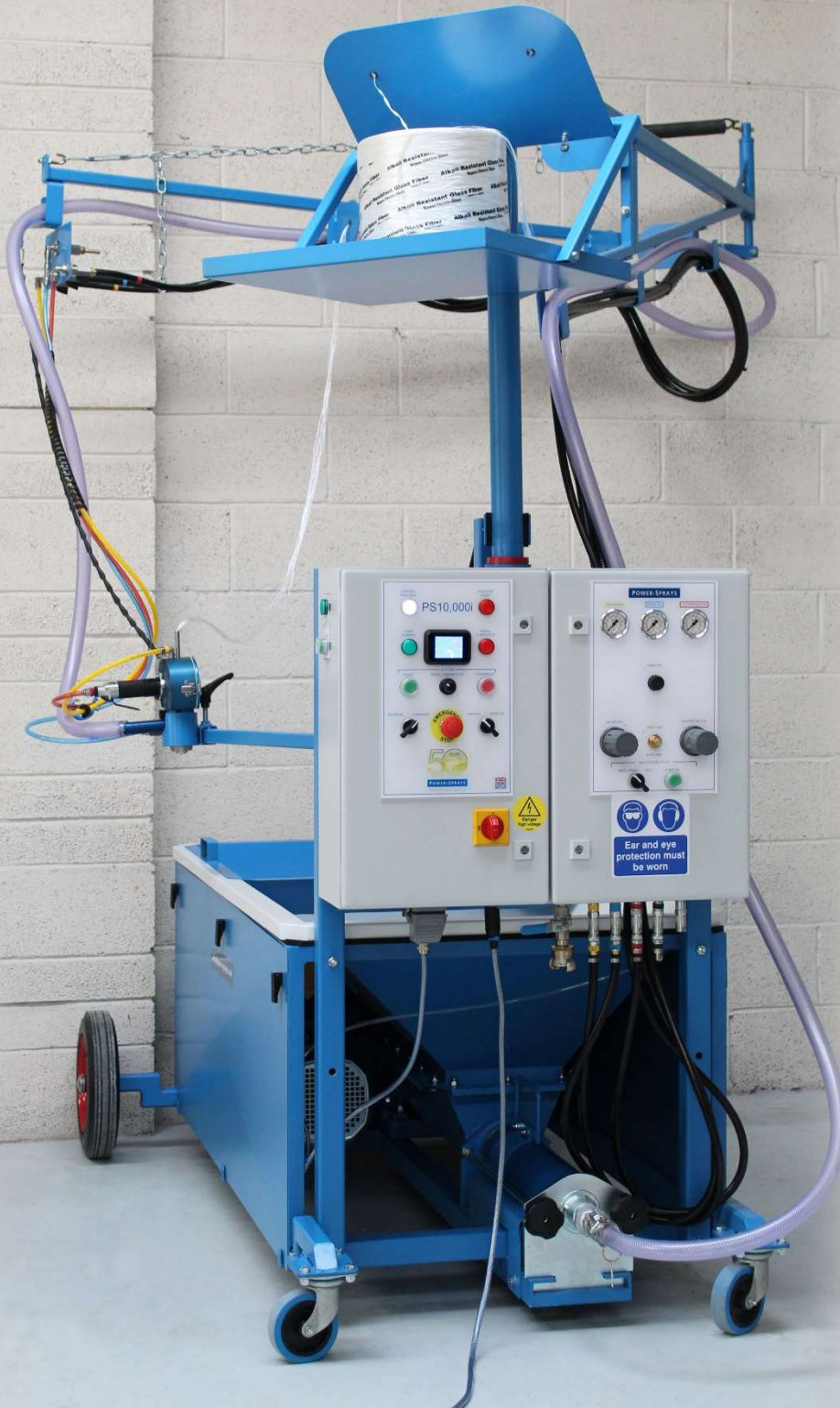

POWER-SPRAYS

3.5m long articulated boom, for maximum flexibility during spraying

Rovings tray, with capacity for four 20kg rovings

Supplied with the Concentric Spray Gun and LW Facing Coat Spray Gun as standard

IP66 rated control panels, with advanced calibration functions

Extra large, low level hopper, with capacity for 300kg of slurry

Progressive cavity pump, with extra large rotor and stator, gives a consistent output, ideal for hand-spray GRC

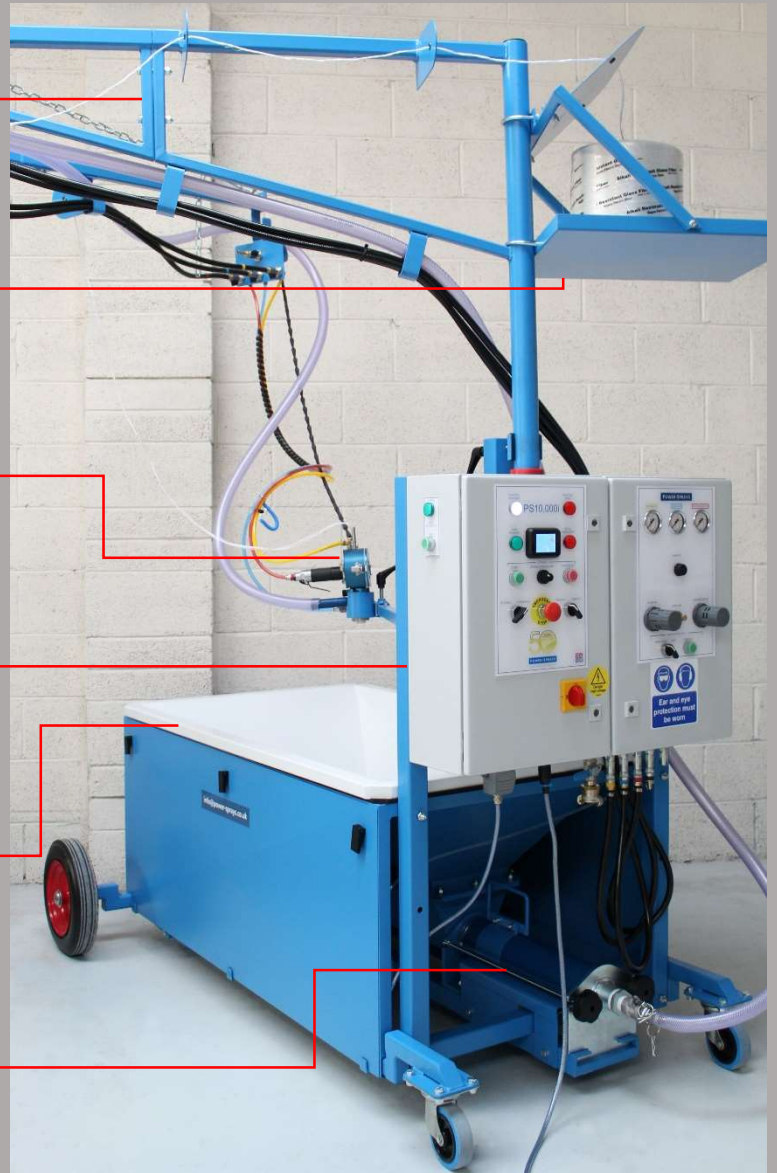

Boom brake gives more control over the position of the articulated boom

Adjustable Concentric Gun holder provides a secure location for the gun when not spraying, and for the "bucket test"

4.0kW, IP55 rated motor, with variable speed control

Vibrator to help the material flow continuously

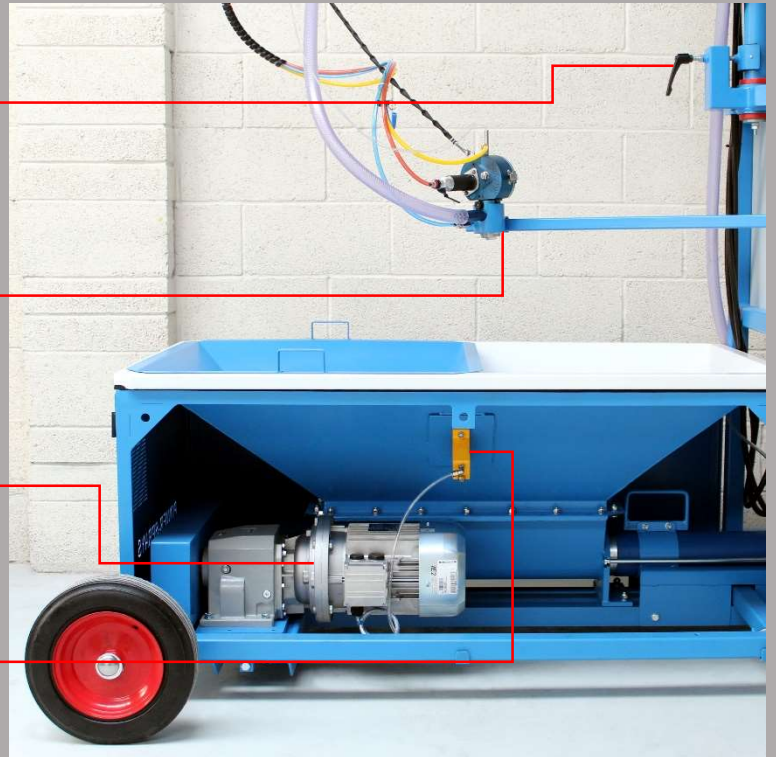

Transparent, reinforced slurry hose, for ease of cleaning

Quick release couplings allow rapid hose removal for cleaning

Stator removal tool to assist with cleaning and maintenance

Quick release latches and removeable safety panels, for maintenance access

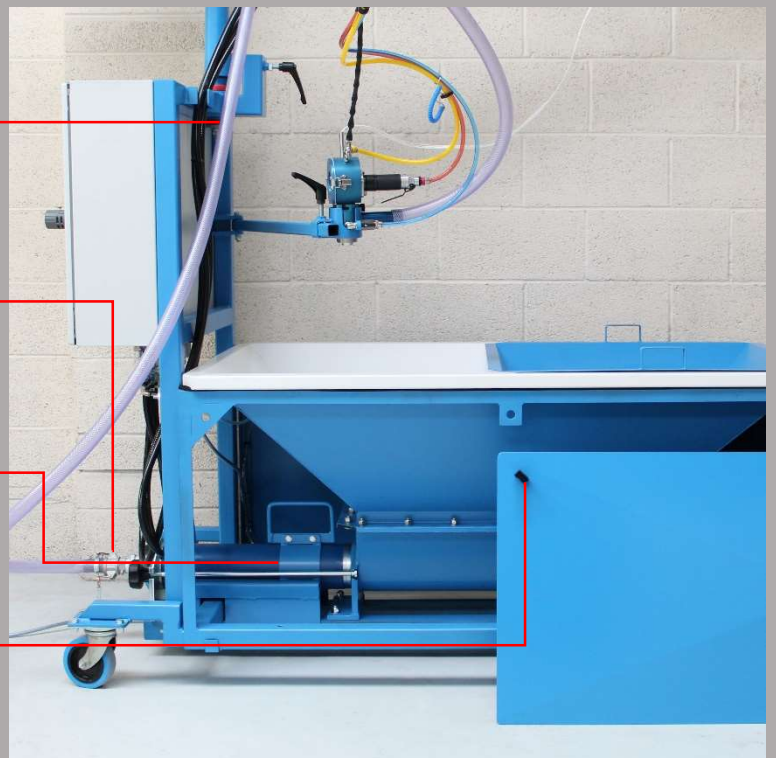

Material sieve to filter large cement particles, reducing blockages

Low level hopper (80cm high)

Highly manoeuvrable, supported on castors and solid rubber wheels

Moving parts guarded for added safety

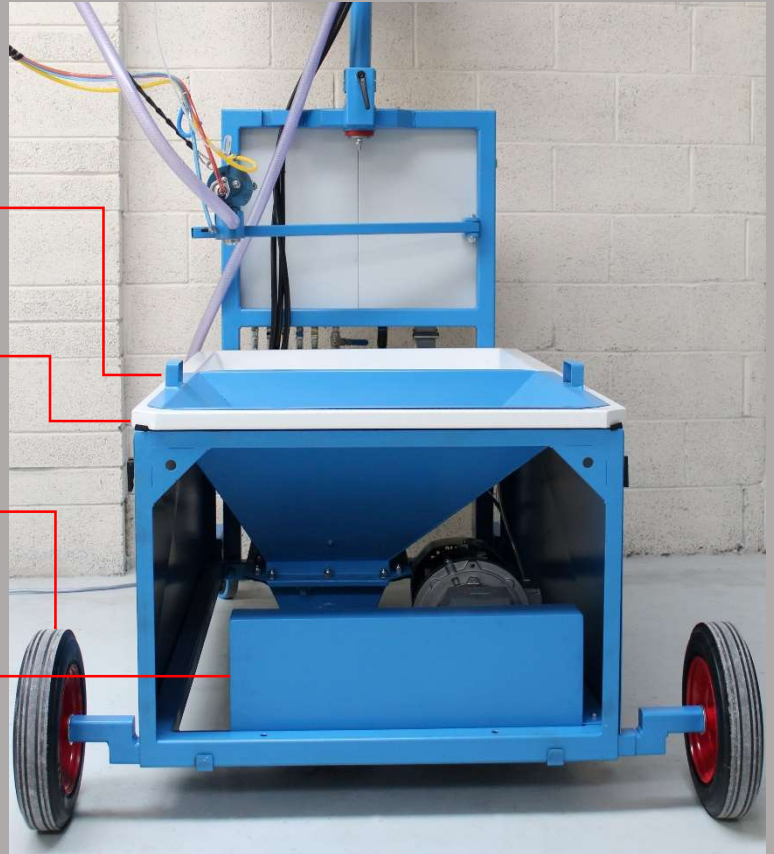

Heavy duty spring easily supports the weight of the boom, gun and hoses

Tension adjuster allows height of the boom to be altered

Hard wearing eyelets prevent the fibre from snagging

2m clearance

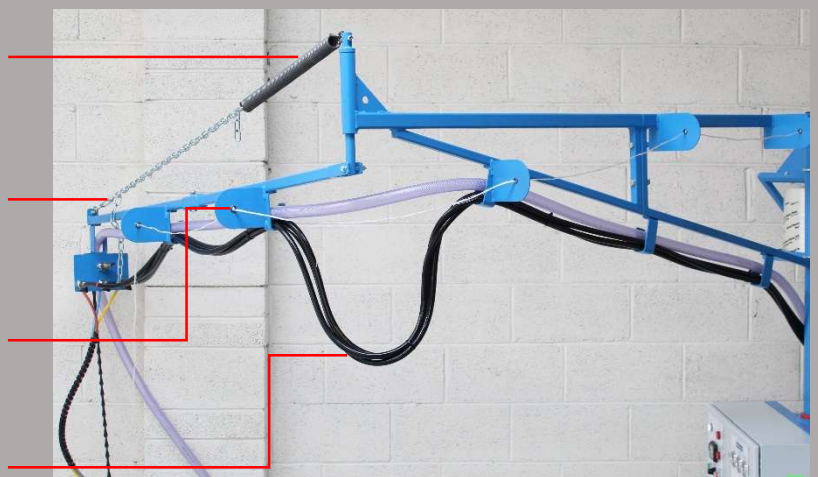

LCD screen with precise speed readout

Speed control via inverter

Reverse mode, to help remove blockages

Manual and remote modes for spraying/calibration

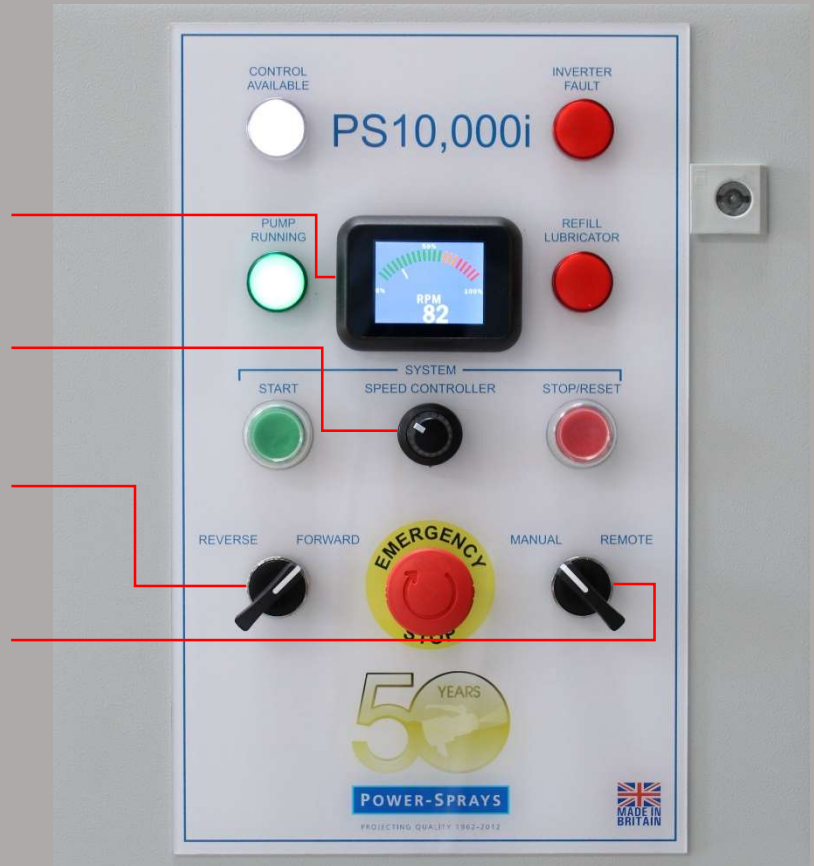

Individual, colour-coded air gauges

Bucket Test – provides a timer for 30 seconds, for calibration of the slurry output

Individual airline controls, to fine-tune the fibre output and spray pattern

Bag Test Mode - automatically runs the chopper motor for 15 seconds, for calibration of the fibre output

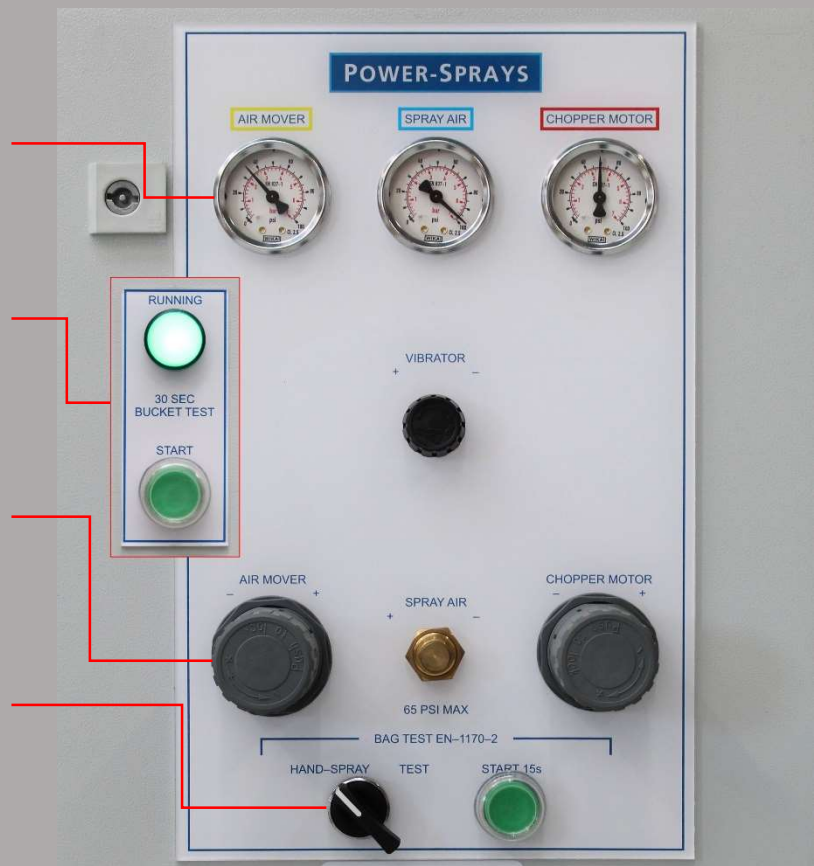

Included Guns

Concentric Spray Gun

Designed for efficient spraying of hand-spray GRC

Removeable atomiser body and nozzle, for easy cleaning

Spray Air Valve also acts as a remote start/stop switch for the spray station

Colour-coded, flexible quick release airlines

Powerful chopper motor – up to 1kg/min fibre output

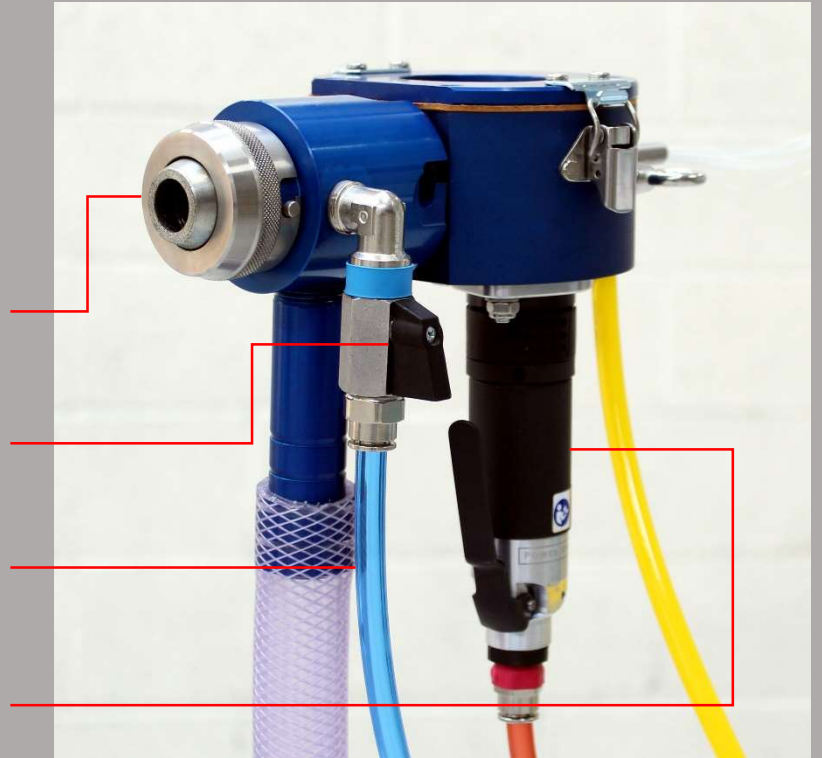

LW Facing Coat Spray Gun

Compact, light-weight gun for spraying mist and face coats in difficult areas

Tapered nozzle for the optimum spray pattern

Removeable nozzle assembly, for easy cleaning



Controls for the Concentric Spray Gun are located on the boom to reduce the weight of the gun

Water inlet to assist with cleaning the gun

Support chain takes the weight of the gun

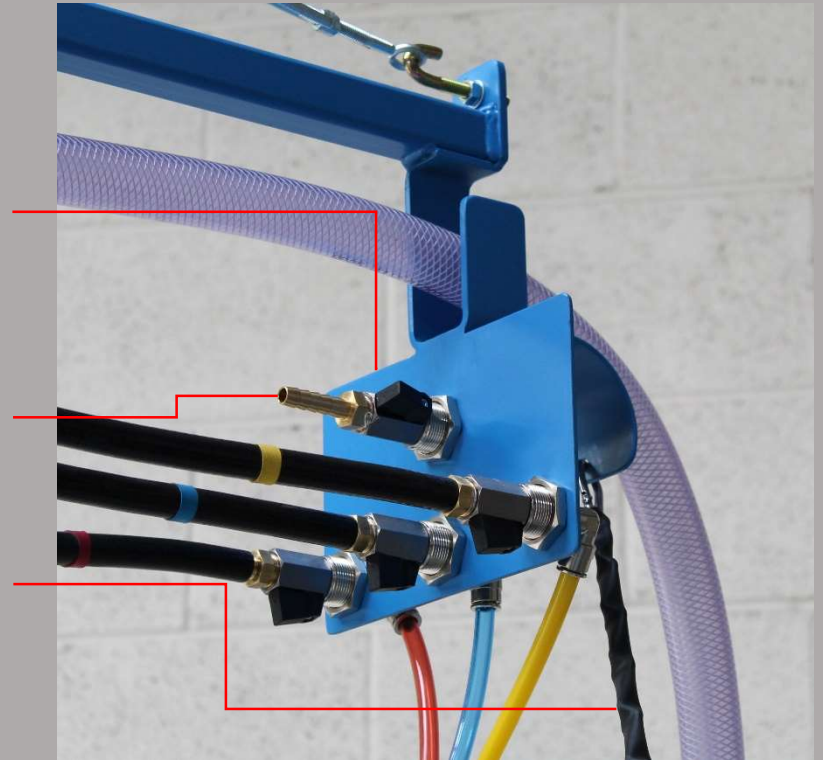

The Power-Sprays PS10,000i GRC/GFRC pump spray station was introduced to supplement the already popular PS9000i spray station. Based on a similar design, the PS10,000i features a larger rotor/stator pump assembly for longer life and less downtime, making it very well suited for high output production

It is easily manoeuvrable and has a low-level, extra-long material hopper for ease of loading. The twin section electric/pneumatic control panel is positioned at a convenient height to access the controls and all the important components are protected within a waterproof cabinet (IP66 rated).

All necessary pneumatic distribution and control systems are built in, including a sensor in the control system which starts/stops the pump when the "Spray Air" is turned on/off at the spray head. A spare pneumatic outlet is provided for air supplies to ancillary tools (e.g. Mist Coat Gun, Vibrated Trowel etc), and an in-line lubricator ensures smooth running of the chopper motor.

The PS10,000i benefits from a machine mounted, fully articulated spray support boom. The progressive cavity rotor/stator pump is driven by a 4.0kW 3-phase electric drive with an inverter based variable speed control system. The integrated pneumatic control systems are designed to operate with both the Concentric Spray Gun and LW Facing Coat Spray Gun, which are also supplied as standard together with spares packs.

Specifications

Weight	480kg
Dimensions	126cm wide x 207cm deep x 150cm high (265cm high with boom fitted)
Pump Speed	0-250RPM, controlled via frequency inverter
Typical Output	12-20kg/minute of GRC
Max output (water)	45L/min at zero back pressure*
Drive	Via reduction gearbox and drive belt
Electric Motor	4.0kW, IP55 rated (hose proof)
Electrical Supply	380/415V 3-phase 50Hz/60Hz standard** Units can be built to suit other 3-phase electricity supplies
Air Consumption	1500L/min (50CFM) approx. at minimum pressure of 7 Bar (100psi)
Air Inlet	Ø 3/4" (19mm) hose tail (airline not included)
Boom Range	3.5m
Slurry Hose	7.5m (24ft) of Ø 25mm (1") hose
Hopper Capacity	150L (approx. 300kg of slurry)
Hopper Loading Height	80cm

*The maximum output when pumping GRC or other cementitious materials will vary according to the fluidity of the mix and the diameter and length of the delivery hose used.

** Generator Supplies: If the electricity supply is from a generator, please consult Power-Sprays, as additional protection may be required.

Why Buy from Power-Sprays?

Support



Experience



Comprehensive Technical Manuals

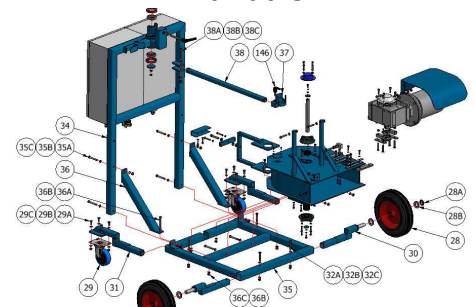

Power-Sprays Ltd

Avonmouth Way, Bristol, BS11 9YA, UK

Tel: +44 (0)117 9820067 Fax: +44 (0)117 9820060

Email: info@power-sprays.co.uk Web: www.power-sprays.com

