

PS38i

Combination GRC Spray Station

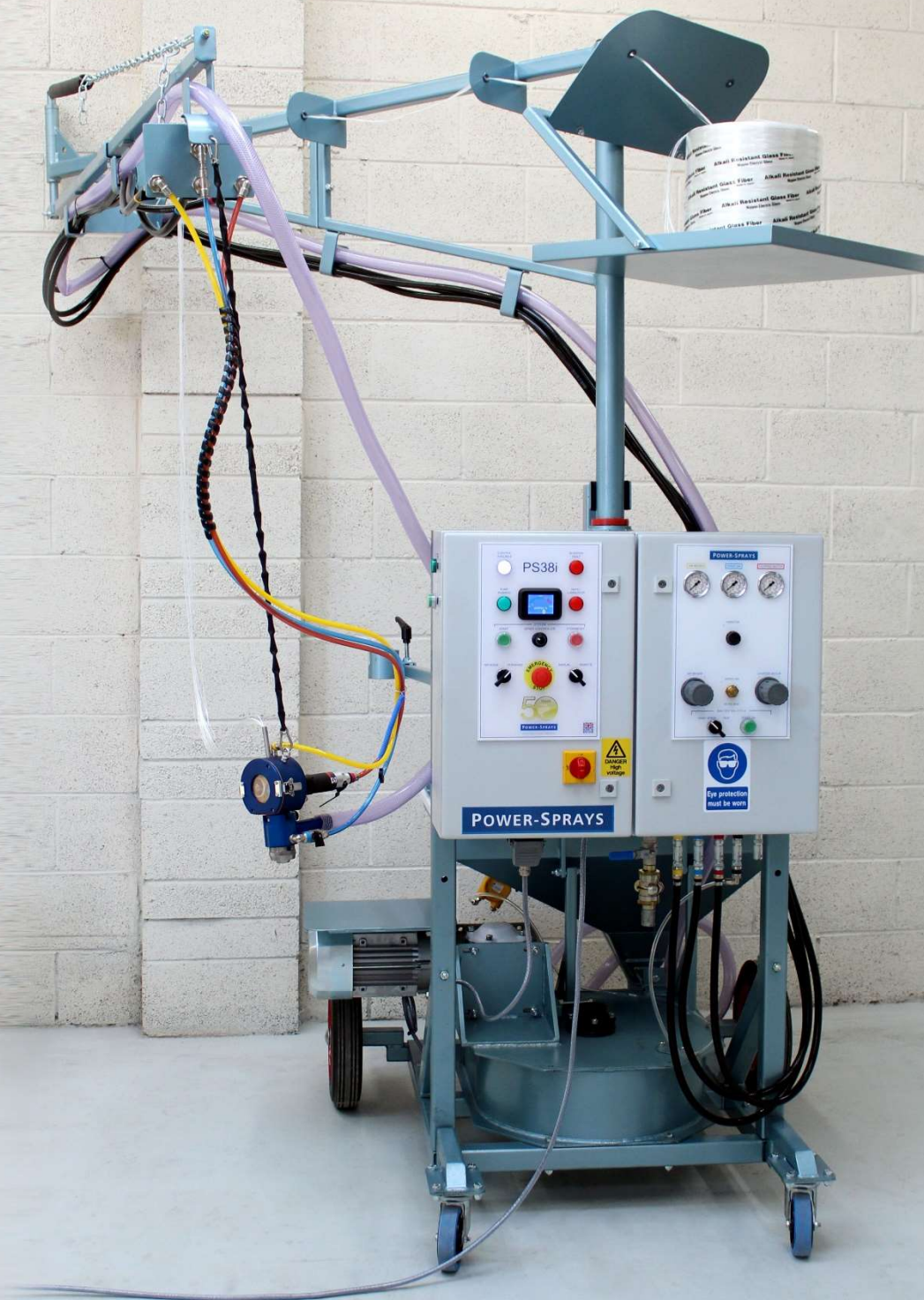

POWER-SPRAYS

3.5m long articulated boom, for maximum flexibility during spraying

Rovings tray, with capacity for four 20kg rovings

Supplied with the Concentric Spray Gun, LW Facing Coat Spray Gun, and MK5A Premix Spray Gun as standard

IP66 rated control panels, with advanced calibration functions

Large, low level hopper, with capacity for over 150kg of GRC

Peristaltic pump allows both slurry and premix GRC to be pumped and sprayed

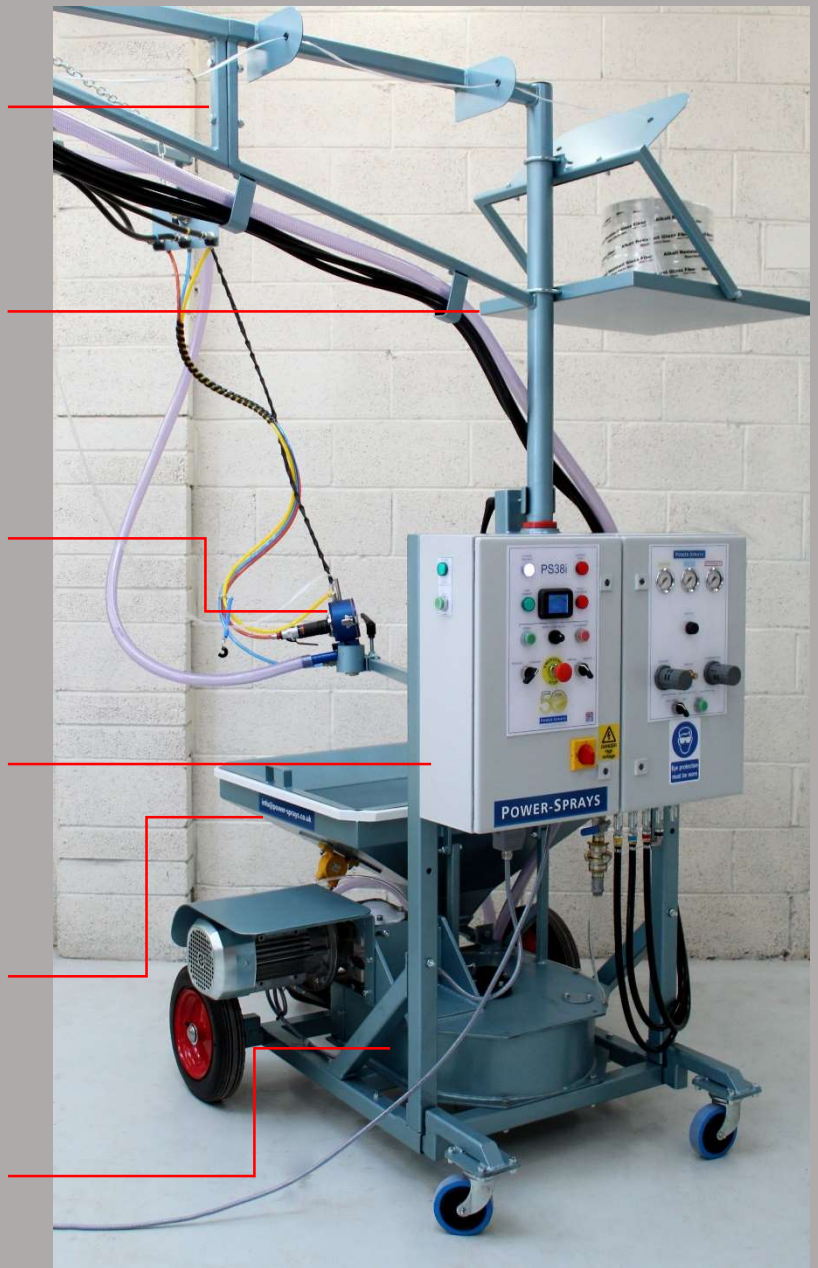

Boom brake gives more control over the position of the articulated boom

Adjustable Concentric Gun holder provides a secure location for the gun when not spraying, and for the "bucket test"

Vibrator to help the material flow continuously

2.2kW, IP55 rated motor, with variable speed control

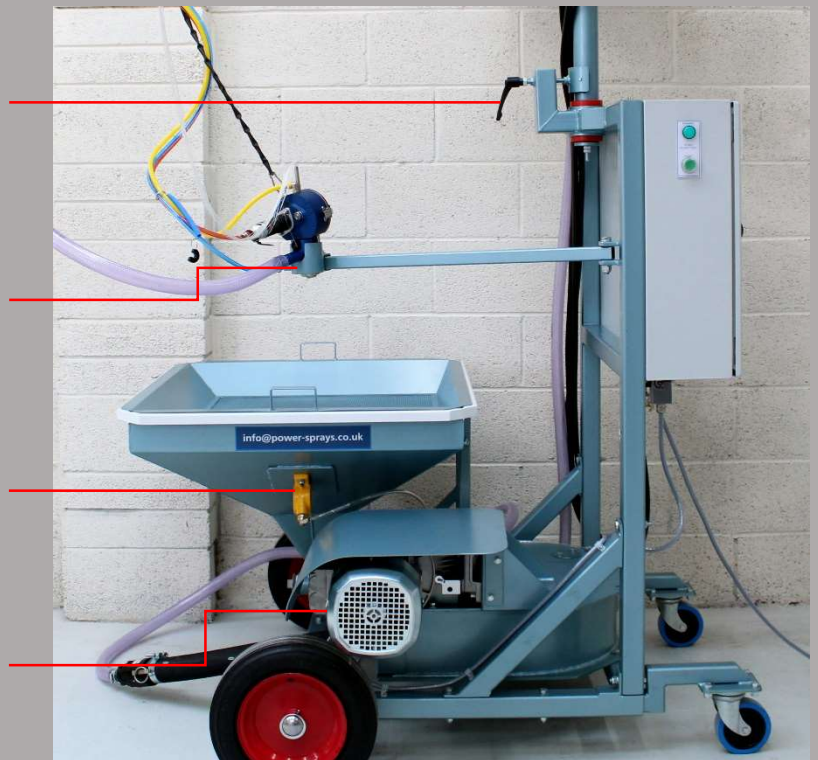

Material sieve to filter large cement particles, reducing blockages

Low level hopper (80cm high)

Quick release couplings allow rapid hose removal, for cleaning and maintenance

Highly manoeuvrable, supported on castors and solid rubber wheels

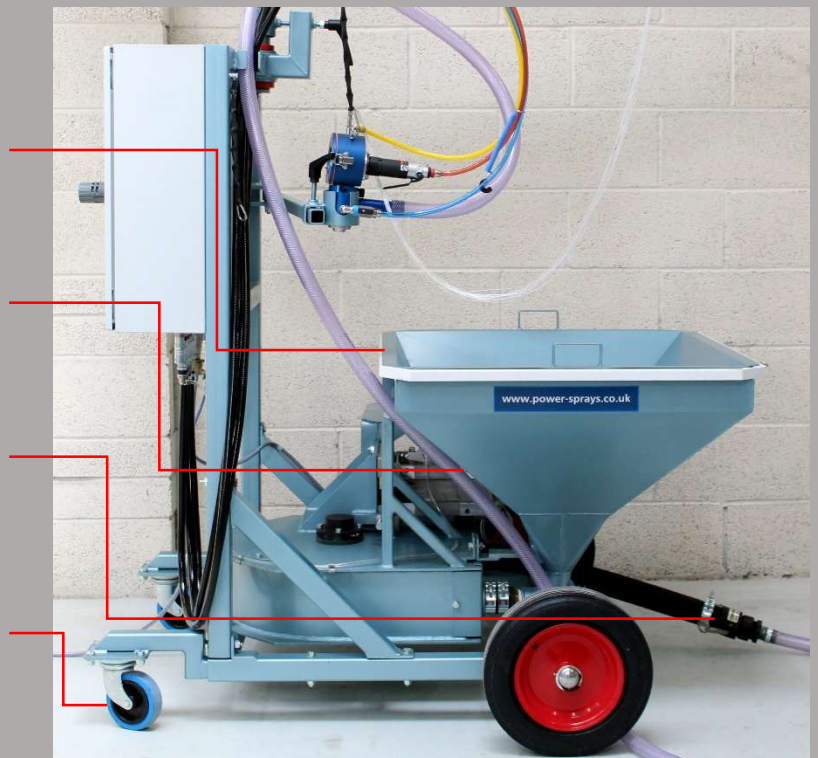

Transparent, reinforced slurry hose, for ease of cleaning

Hopper can be rotated by 90° for maintenance

Multi-roller, low-pulse peristaltic pump

Robust peristaltic hose, with a 12 Bar (180psi) pressure rating and high abrasion resistance

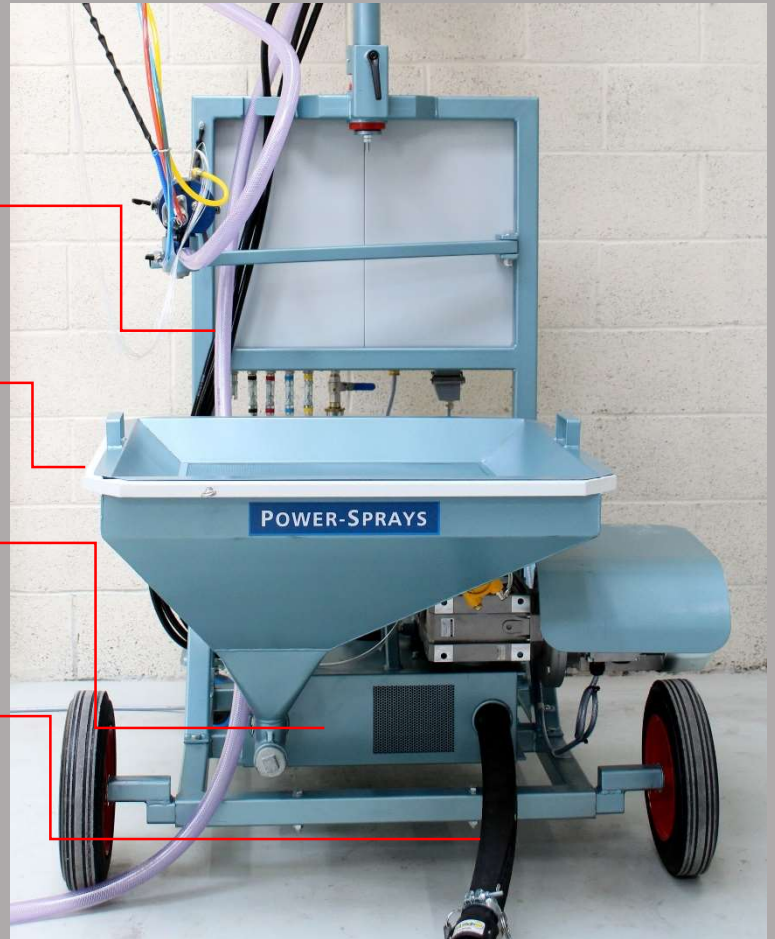

Heavy duty spring easily supports the weight of the boom, gun and hoses

Tension adjuster allows height of the boom to be altered

Hard wearing eyelets prevent the fibre from snagging

2m clearance

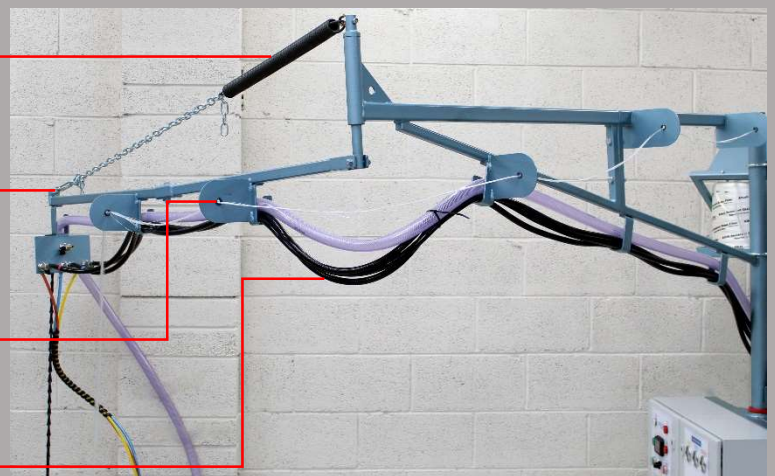

LCD screen with precise speed readout

Speed control via inverter

Reverse mode up to 100% speed, to help remove blockages

Manual and remote modes for spraying/pumping/calibration



Individual, colour-coded air gauges

Bucket Test – provides a timer for 30 seconds, for calibration of the slurry output

Individual airline controls, to fine-tune the fibre output and spray pattern

Bag Test Mode - automatically runs the chopper motor for 15 seconds, for calibration of the fibre output

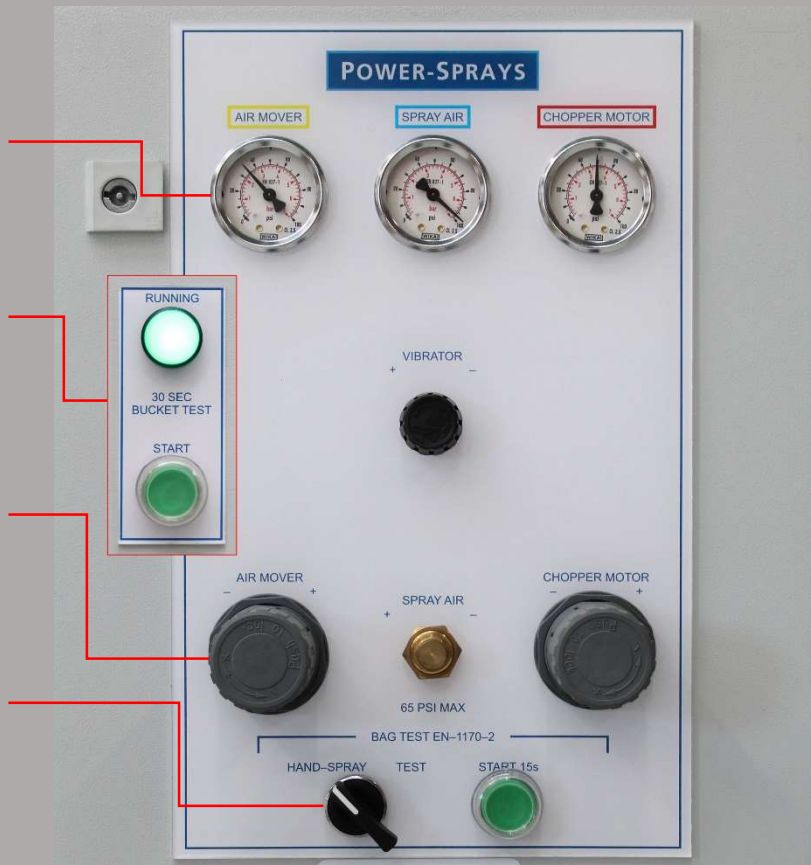

Included Guns

Concentric Spray Gun

Designed for efficient spraying of hand-spray GRC

Removeable atomiser body and nozzle, for easy cleaning

Spray Air Valve also acts as a remote start/stop switch for the spray station

Colour-coded, flexible quick release airlines

Powerful chopper motor – up to 1kg/min fibre output

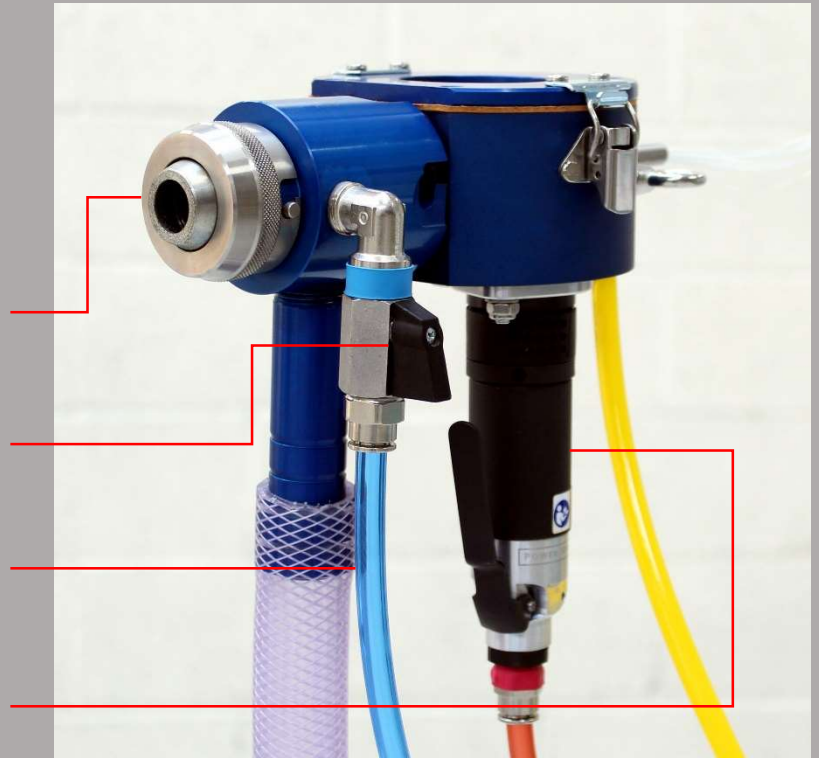

Controls for the Concentric Spray Gun are located on the boom to reduce the weight of the gun

Water inlet to assist with cleaning the gun

Support chain takes the weight of the gun

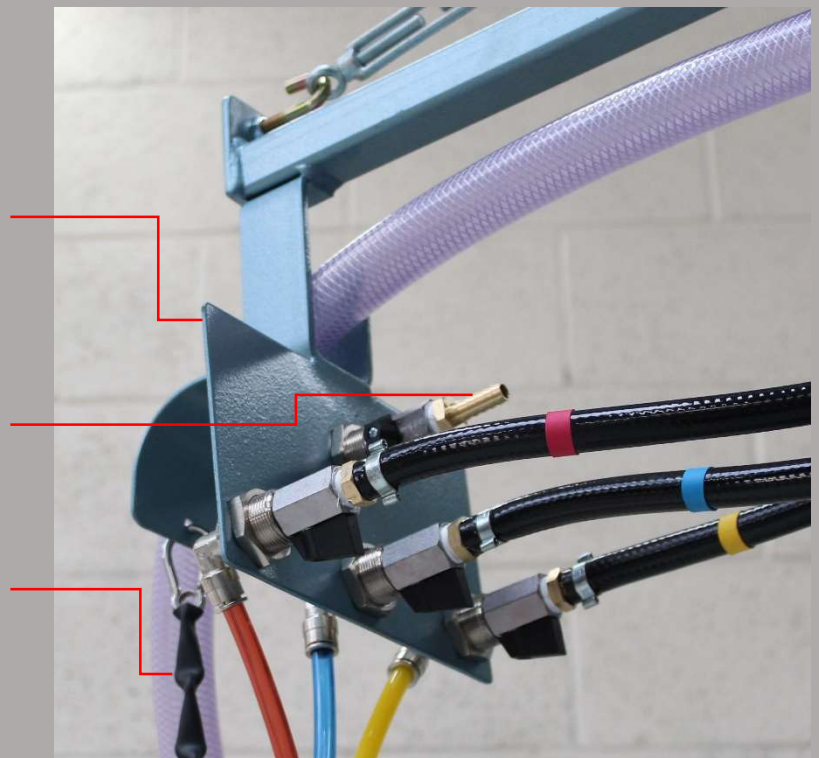

Included Guns

LW Facing Coat Spray Gun

Compact, light-weight gun for spraying mist and face coats in difficult areas

Tapered nozzle for the optimum spray pattern

Removeable nozzle assembly, for easy cleaning



MK5A Premix Spray Gun

Heavy-duty gun for spraying premix GRC

Extra-wide reinforced hose and separate airlines (10m lengths included as standard)

Removeable nozzle assembly, for easy cleaning



Variants of the PS38

PS38B Premix Spray Station

Ideal for pumping and spraying premix GRC. The PS38B has all the same features as the PS38i, but does not include the articulated boom, Concentric Spray Gun or the LW Facing Coat Spray Gun



PS38P Pneumatic Spray Station

Designed for applications where electricity is not available; the PS38P uses compressed air for all its functions. Available with an optional Powermix 100 mixer mounted above the hopper



Sprayed Premix is now a widely accepted method for the manufacture of GRC (Glassfibre Reinforced Concrete) products. The PS38i Combination Spray Station allows GRC producers the complete flexibility of having one spray station that can be used for both Spray Premix and Traditional Hand Spray GRC. It can also be used for pumping premix GRC directly to moulds.

The PS38i features a peristaltic pump with "multi-roller low pulse" technology. These pumps are ideal for conveying premix GRC and other fibrous materials like Glass Reinforced Gypsum. There are no moving parts in contact with the material and so the strand integrity of the fibre is maintained.

Cleaning is simplicity itself; a sponge ball (supplied) is pumped through the pump and hose 2 or 3 times and the pump is clean. When necessary, the pump's high-performance internal hose is easily removed for inspection or replacement. This internal hose has excellent pressure capabilities (12 Bar / 180psi) and abrasion resistance. Unlike many specialist hoses, it is very economic and offers outstanding value.

The PS38i benefits from a machine mounted, fully articulated spray support boom. The pump is driven by a 2.2kW 3-phase electric drive with an inverter based variable speed control system. The integrated pneumatic control systems are designed to operate with both the MK5A Premix Spray and Concentric Spray Guns, which are also supplied as standard together with spares packs.

Specifications

Weight	420kg
Dimensions	120cm wide x 143cm deep x 150cm high (265cm high with boom fitted)
Pump Speed	0-18RPM, controlled via frequency inverter
Typical Output	12-20kg/minute of GRC
Max output (water)	18L/min at zero back pressure*
Drive	Via reduction gearbox and chain wheel
Electric Motor	2.2kW, IP55 rated (hose proof)
Electrical Supply	380/415V 3-phase 50Hz/60Hz standard** Units can be built to suit other 3-phase electricity supplies
Air Consumption	1500L/min (50CFM) approx. at minimum pressure of 7 Bar (100psi)
Air Inlet	Ø 3/4" (19mm) hose tail (airline not included)
Boom Range	3.5m
Slurry Hoses	10m (30ft) of Ø 25mm (1") hose (for hand-spray GRC) 10m (30ft) of Ø 31mm (1¼") hose (for premix GRC)
Hopper Capacity	80L (> 150kg of GRC)
Hopper Loading Height	80cm

*The maximum output when pumping GRC or other cementitious materials will vary according to the fluidity of the mix and the diameter and length of the delivery hose used.

** Generator Supplies: If the electricity supply is from a generator, please consult Power-Sprays, as additional protection may be required.

Why Buy from Power-Sprays?

Support



Experience



Comprehensive Technical Manuals

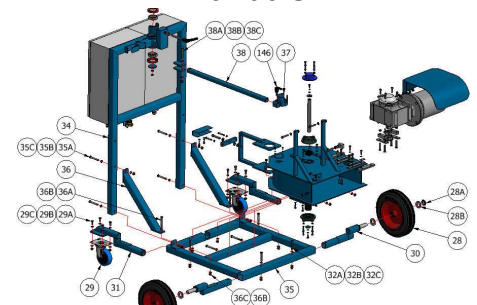

Power-Sprays Ltd

Avonmouth Way, Bristol, BS11 9YA, UK

Tel: +44 (0)117 9820067 Fax: +44 (0)117 9820060

Email: info@power-sprays.co.uk Web: www.power-sprays.com

